

# SWT-2000

## 2 Channel Speed Switch/Transmitter

- 2 Speed switches in one..
  - Monitor and protect two separate machines
  - Provide redundant speed protection on one machine
- Flexible - Allows multiple setup configurations
- Dual speed measurement/protection
- DIN rail mounting

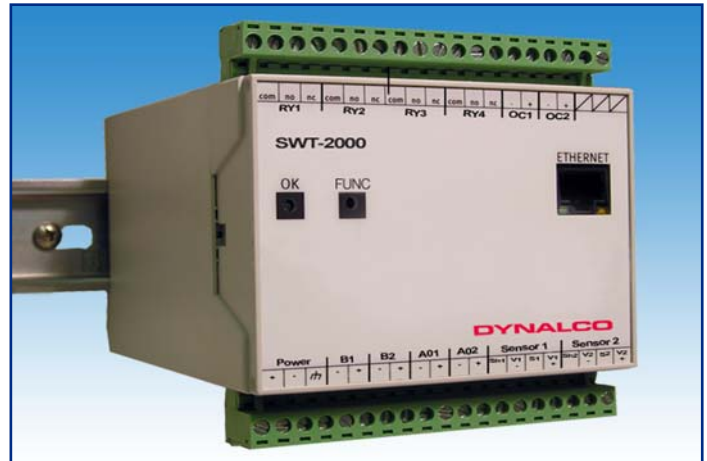

### Features

- 2 frequency + 2 binary inputs
- 2 current (4-20 mA) outputs
- 4 relay and 2 open collector outputs
- Open pickup sensor
- 4 parameter sets each with 6 set-points for almost limitless applications
- x1, x2 or x4 repeater outputs
- Fully isolated I/O
- High accuracy speed measurement: 0.002% for set-points and 0.1% for analog signals
- Programmable logical, diagnostic and measurement functions
- Fast 8 ms reaction time on overspeed
- Compatible with passive and active mag pickups
- Plug in terminals
- 18-36 VDC or 90-264 VAC power supply
- Ethernet interface - configuration via Windows® software
- 0Hz - 50kHz operating frequency range

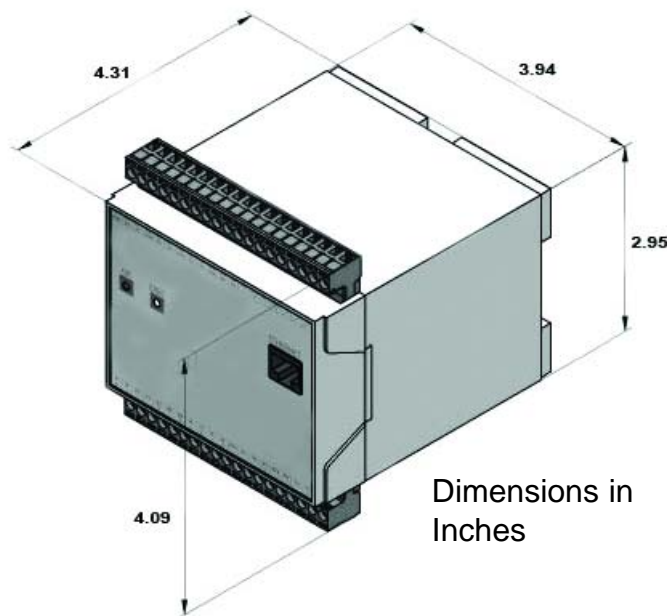

# SWT-1000 / SWTD-1000

## Speed Switch/Transmitter with Optional Display

- 4-20mA isolated output - loop isolator not required
- Single relay setpoint for over speed protection
- Configurable via Windows® software

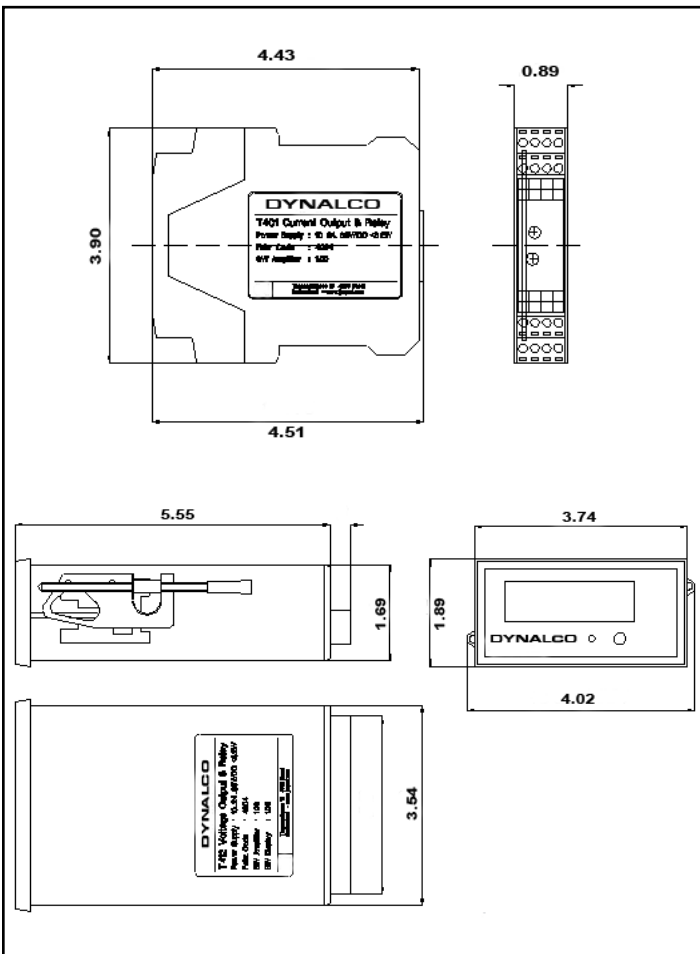

## Features

- Converts frequency to an analog signal
- Output configurable for 4-20 mA or 0-10 VDC
- 0Hz - 50kHz operating frequency range
- Integrated backlit display (SWTD-1000)
- 2 possible relay set-point configuration sets (A & B) for start up / run, controlled via binary inputs
- Open pickup sensor warns against failed pickup
- Plug in terminals for easy installation
- Isolated signal input with automatic trigger level adjustment ensures accurate speed measurement
- Open collector repeater output provides signal to external devices
- Accuracy 0.05% for setpoints, 0.5% for analog signals
- Fast response to over-speed conditions, 10.5ms typical
- Adaptive input signal sensitivity provides high noise immunity
- Integrated 2 or 3 wire sensor monitoring and system watchdog

**DYNALCO**

CRANE

A division of Crane Co.

Toll Free 800.368.6666 (US & Canada)  
Main 954.739.4300 • Fax 954.484.3376 • www.dynalco.com  
3690 NW 53rd Street, Ft. Lauderdale, FL 33309 USA

